

EC-ITF

The EC Induction Thrust Fan



Introduction

The new EC induction thrust car park fan from Flaktwoods with dual impeller is the most compact fan suitable for low height car parks. Combined with dual centrifugal impellers and EC motors makes the fan 100% speed controllable via 0-10V signal. The induction fan can be used for general ventilation purpose, carbon monoxide monitoring and cold smoke extraction in closed car park buildings.

Technical Parameters

Thrust	12N
Voltage	230V
Frequency	50 / 60 Hz
Phase	1 ph
Absorbed Power	317 W
Full load current	2.48 A
Impeller speed	2660 rpm
Max Operating Temperature	60°C
Motor type	EC
Enclosure / Insulation Class	IP54 / B
Sound Pressure	68 dB(A) at 2 m (free field)
Weight	15 kg

Construction Details

The EC Induction Thrust Fan (EC-ITF) is having energy efficient dual EC technology motors for the perfect ventilation. The fan casing is made up of galvanized steel and fitted with galvanized steel ceiling mount for easy mounting. The induction fan is having external terminal box which is internally connected to the motor side and is also fitted with inlet protection guards. The twin parallelly connected impellers are made from plastic and perfectly balanced as per grade G4.0 to avoid any type of unnecessary vibration.

Dimensional Details

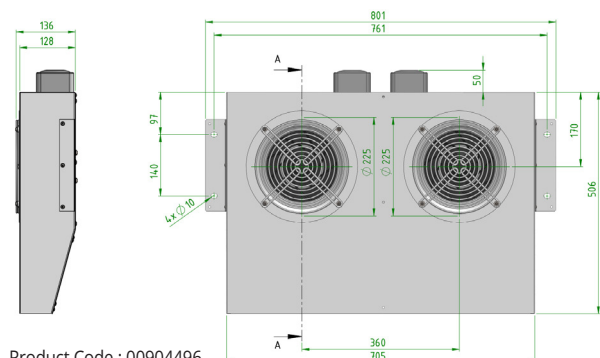

Product Code : 00904496